

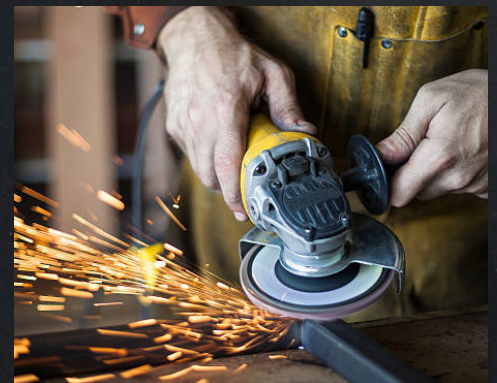



THE LEVY SUITE OF HOSPITALITY PRODUCTS IS DESIGNED & MANUFACTURED HERE IN THE USA. FABRICATED FROM BLACKENED-OXIDIZED STEEL, CUSTOM-STAINED BIRCH, AND NSF APPROVED PLASTIC LAMINATES, THIS HEAVY DUTY CONSTRUCTION ENSURES DURABILITY TO STAND THE TEST OF TIME. OUR MODERN-INDUSTRIAL APPROACH OFFERS A LOOK THAT CAN BE TAILORED TO COMPLIMENT ANY SPACE. CHOOSE FROM A VARIETY OF OUR IN-HOUSE FINISHES OR CUSTOMIZE TO YOUR SPECIFICATIONS.



features

- Blackened Steel Frame
- Heavy Duty Construction
- No need for Linens
- 4" Casters with Black Polyurethane Tread
- Allows For Easy Back of House Set Up

 **MADE IN THE USA**

Choose from our standard finishes. Custom finishes available.



T-Fold Table



Retail T-Fold Table



Chef's Presentation Table



Pedestal Table



Service Cart



Large Service Cart



Hot Food Service Cart



Portable Back Bar



Portable Side Bar



Portable Bar



Partition Wall



Chain Partition Wall

Call us for more info: 1-800-606-6146 -or- sales@coreconceptsinc.com



Portable Side Bar - 28"l x 28"d x 34"h

Pedestal Table - 36"l x 36"d x 36"h and 36"l x 36"d x 42"h

Partition Wall - 98"l x 33.5"d x 90"h

T-Fold Tables - 84"l x 31.5"d x 30"h - shown with and without retail rail

* All shown in Franklin finish



Portable Bar Cart - 69.5"l x 30"d x 42"h

Portable Back Bar - 66.5"l x 24"d x 87"h

Portable Side Bar - 28"l x 28"d x 34"h

Pedestal Table - 36"l x 36"d x 36"h and 36"l x 36"d x 42"h

* All shown in Franklin finish

Call us for more info: 1-800-606-6146 -or- sales@coreconceptsinc.com



Portable Side Bar - 28"l x 28"d x 34"h

Portable Bar Cart - 69.5"l x 30"d x 42"h

Portable Back Bar - 66.5"l x 24"d x 87"h

Chain Partition Wall - 62"l x 28-1/2"d x 82"h

Pedestal Table - 36"l x 36"d x 36"h and 36"l x 36"d x 42"h

* All shown in Franklin finish

Call us for more info: 1-800-606-6146 -or- sales@coreconceptsinc.com



*** Shown in Franklin**



*** Tables fold up for easy storage**

T-Fold Table

features

- Blackened Steel Frame
- Heavy Duty Construction
- No need for Linens
- 4" Casters with Black Polyurethane Tread
- (2) Locking Casters
- Allows For Easy Back of House Set Up
- 20 Amp Multi Power Strip with 15' Cord and (6) Outlets
- Cable Management Trough
- Custom Square Grommet Holes with Matching Plug Lanyard
- Magnets on Feet for Table Nesting

Overall Dimensions - 84"l x 31.5"d x 30"h

Choose from our standard finishes. Custom finishes available.

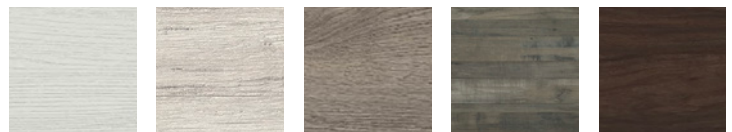

Yarmouth Nantucket Foxboro Franklin Brookline

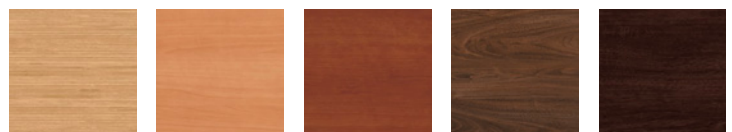

Cambridge Quincy Salem Walpole Boston

Call us for more info: 1-800-606-6146 or sales@coreconceptsinc.com

T-Fold Table

 **MADE IN THE USA**



20 Amp Multi Power Strip with (6) Outlets and a 15' Grounded Cord, Hidden Inside a Steel Cable Management Trough

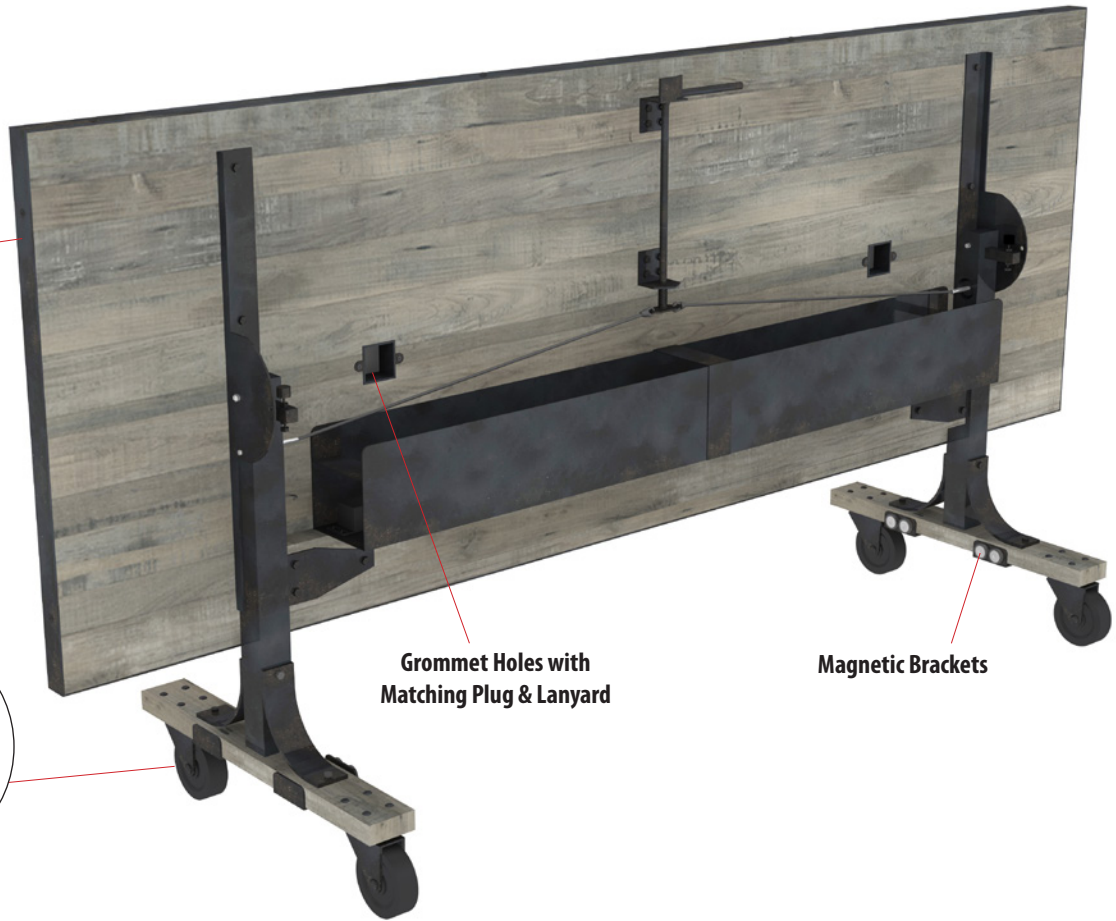

Oxidized Steel Bumper

Grommet Holes with Matching Plug & Lanyard

Magnetic Brackets



Non-Marring Casters

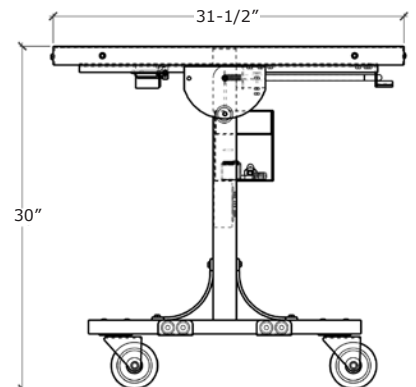
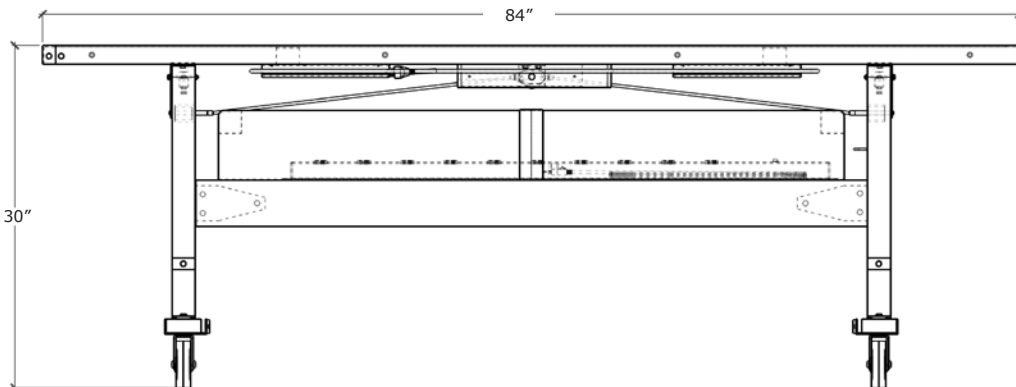

Call us for more info: 1-800-606-6146 -or- sales@coreconceptsinc.com

T-Fold Table

Ask About Custom Finishes

 **MADE IN THE USA**



Yarmouth



Cambridge



Nantucket



Quincy



Foxboro

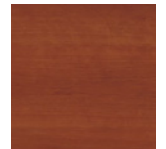

Salem

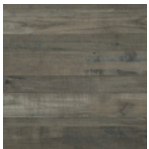

Franklin

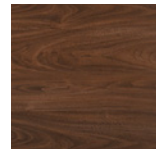

Walpole

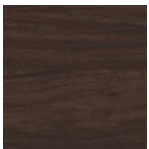

Brookline

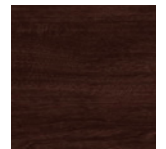

Boston

Call us for more info: 1-800-606-6146 -or- sales@coreconceptsinc.com

Retail T-Fold Table

features

- Blackened Steel Frame
- Heavy Duty Construction
- No need for Linens
- 4" Casters with Black Polyurethane Tread
- (2) Locking Casters
- Allows For Easy Back of House Set Up
- 20 Amp Multi Power Strip with 15' Cord and (6) Outlets
- Cable Management Trough
- Custom Square Grommet Holes with Matching Plug Lanyard
- Magnets on Feet for Table Nesting
- Overhead Retail Rail with (16) hooks

Table Dimensions - 84"l x 31.5"d x 30"h

Overall Dimensions - 66"w x 28"d x 82"h



***Shown in Franklin**

Choose from our standard finishes. Custom finishes available.



***Tables fold up for easy storage**

Call us for more info: 1-800-606-6146 or sales@coreconceptsinc.com

Retail T-Fold Table

 **MADE IN THE USA**



20 Amp Multi Power Strip with (6) Outlets and a 15' Grounded Cord, Hidden Inside a Steel Cable Management Trough

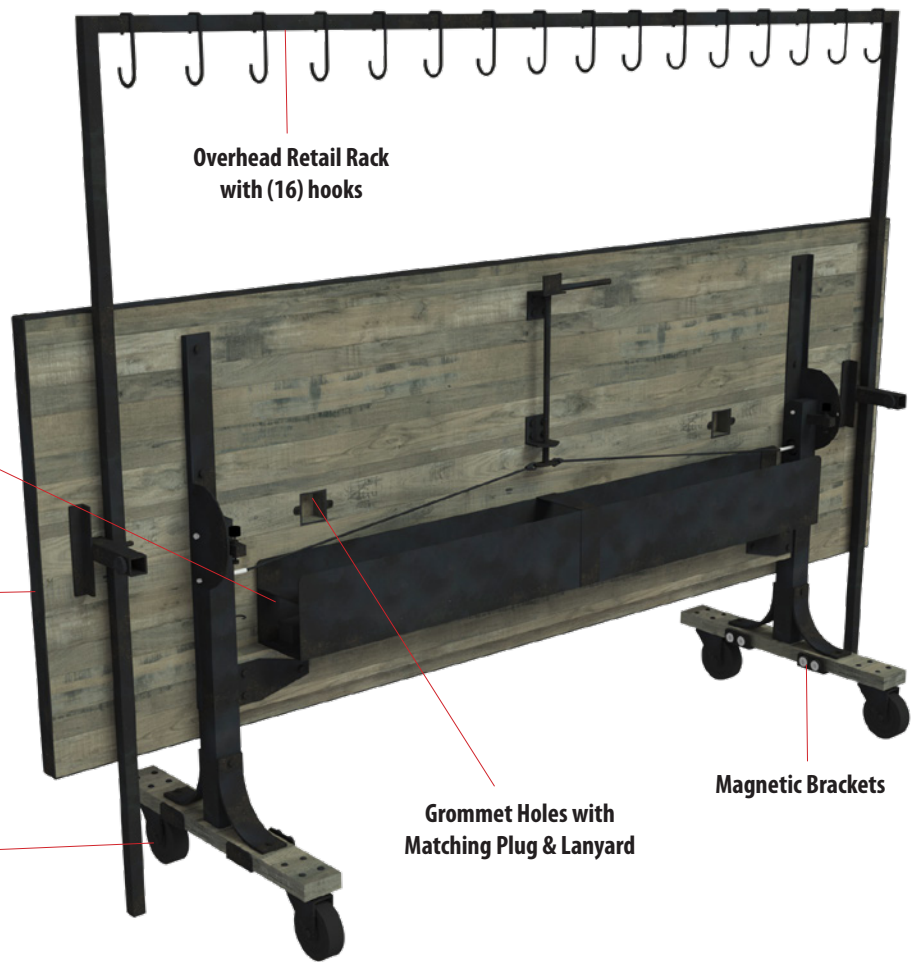

Non-Marring Casters

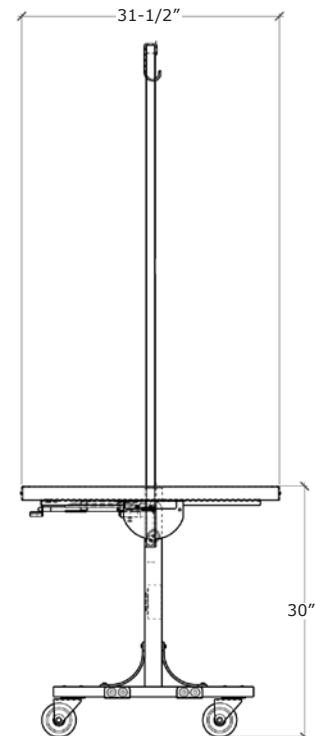
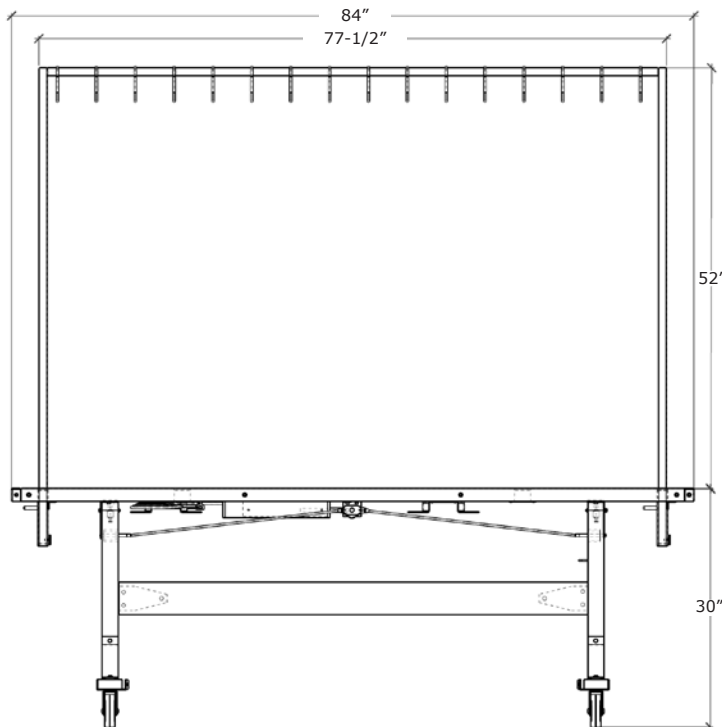

Call us for more info: 1-800-606-6146 -or- sales@coreconceptsinc.com



*Shown in Franklin

Pedestal Table

features

- Blackened Steel Frame
- Heavy Duty Construction
- No need for Linens
- (3) Leveling Feet

Overall Dimensions - 36"l x 36"d x 36"h

or

Overall Dimensions - 36"l x 36"d x 42"h

Choose from our standard finishes. Custom finishes available.

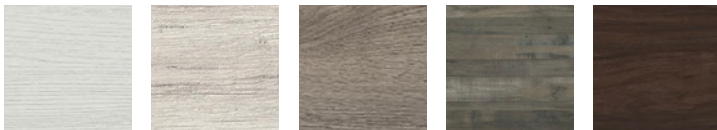

Yarmouth

Nantucket

Foxboro

Franklin

Brookline

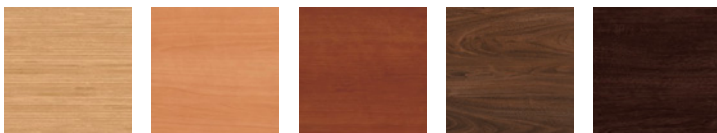

Cambridge

Quincy

Salem

Walpole

Boston

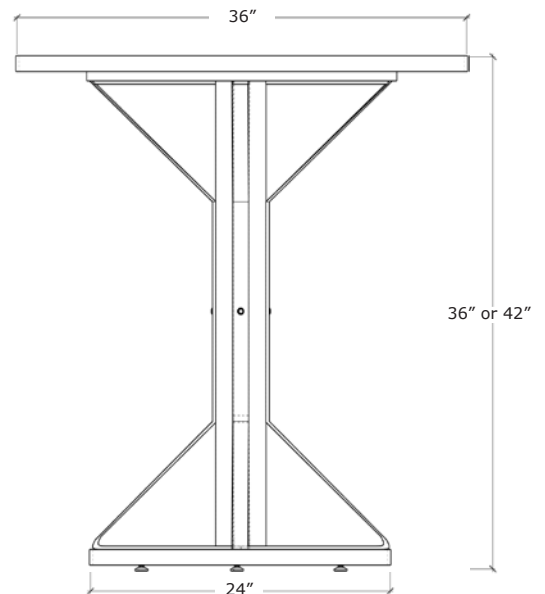

*Wide Base with Leveling Feet

Call us for more info: 1-800-606-6146 or sales@coreconceptsinc.com



*** Shown in Calacatta**

Chef's Presentation Table

features

- 3" Quartz Countertop
- Legs made with 3" Steel Tubing
- Steel bumper to protect Quartz Edge

Overall Dimensions - 96"l x 42"d x 36"h

Choose from our standard finishes.
Custom finishes available.



Calacatta



Bianco

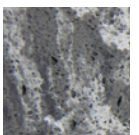

Moon



Call us for more info: 1-800-606-6146 -or- sales@coreconceptsinc.com



*Shown in Franklin

Service Cart

features

- Blackened Steel Frame
- Heavy Duty Construction
- 4" Casters with Black Polyurethane Tread
- (2) Locking Casters
- Allows For Easy Back of House Set Up
- Removable Center Shelf

Overall Dimensions - 34"l x 20"d x 34"h



*Removable Center Shelf

Choose from our standard finishes. Custom finishes available.

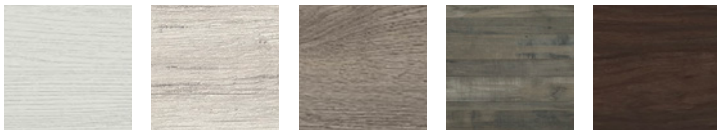

Yarmouth Nantucket Foxboro Franklin Brookline

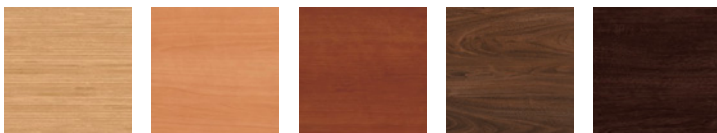

Cambridge Quincy Salem Walpole Boston

Call us for more info: 1-800-606-6146 or sales@coreconceptsinc.com

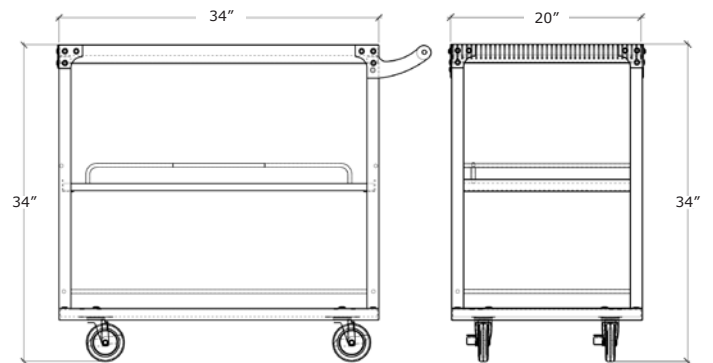



*Shown in Franklin

Large Service Cart

features

- Blackened Steel Frame
- Heavy Duty Construction
- 4" Casters with Black Polyurethane Tread
- (2) Locking Casters
- Allows For Easy Back of House Set Up
- Removable Center Shelf
- Over 600 lbs Carrying Capacity

Overall Dimensions - 40"l x 32"d x 32"h



*Removable Center Shelf

Choose from our standard finishes. Custom finishes available.

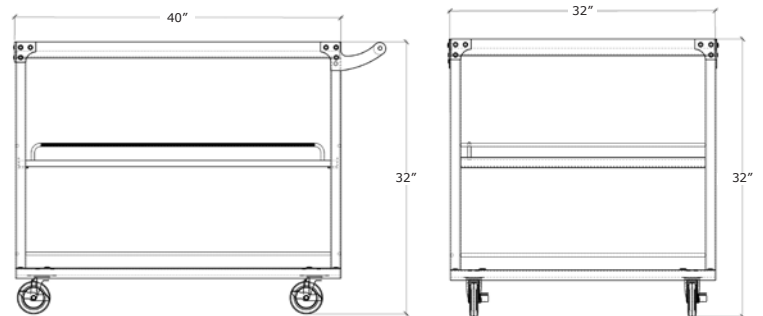

Call us for more info: 1-800-606-6146 or sales@coreconceptsinc.com



*Shown in Franklin

Hot Food Service Cart

features

- Blackened Steel Frame
- Heavy Duty Construction
- 4" Casters with Black Polyurethane Tread
- (2) Locking Casters
- Stainless Steel Top
- Corner Bumpers
- (2) Heat Sources
- Insulated Interior with Internal Temperature Thermometer
- Sliding Shelves

Overall Dimensions - 44"l x 30"d x 39.5"h

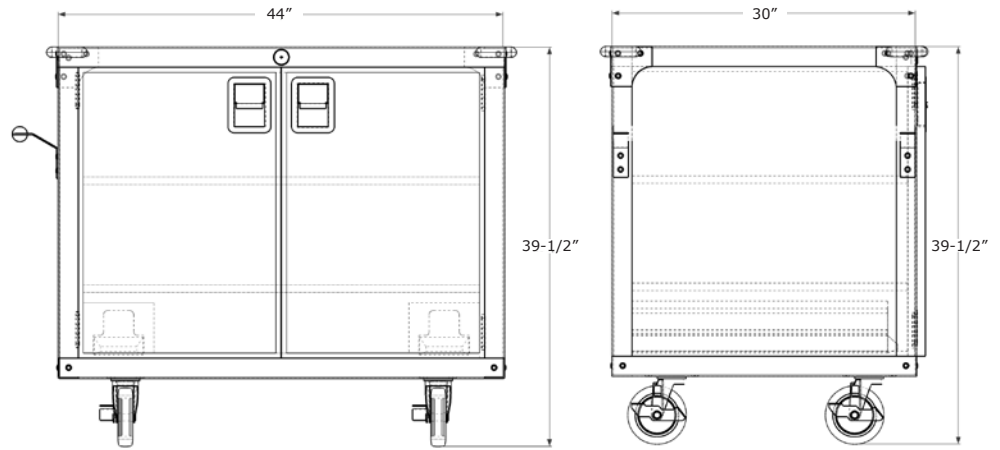

Choose from our standard finishes. Custom finishes available.



*Heated Interior

Call us for more info: 1-800-606-6146 or sales@coreconceptsinc.com



Portable Bar Cart

features

- Blackened Steel Frame
- Heavy Duty Construction
- 4" Casters with Black Polyurethane Tread
- (2) Locking Casters
- Under Counter LED Light Strip
- (2) 16" w x 4" h x 4.5" d Speed Rails
- (2) Covered Ice Bins with Drainage Containers

Overall Dimensions - 69.5"l x 30"d x 42"h

*Shown in Franklin

Choose from our standard finishes. Custom finishes available.



Call us for more info: 1-800-606-6146 or sales@coreconceptsinc.com

Portable Bar Cart

 **MADE IN THE USA**

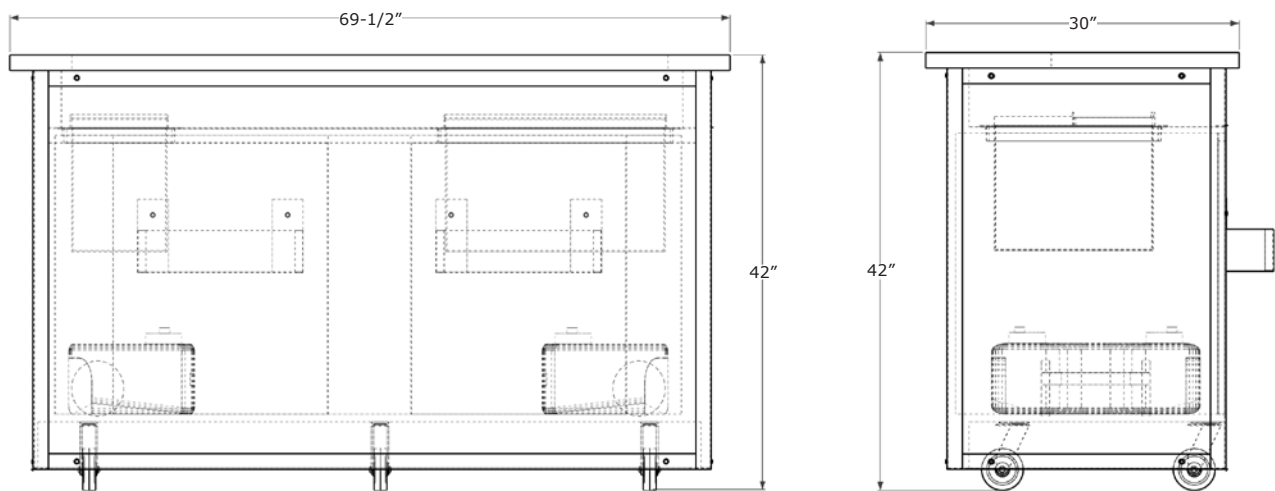
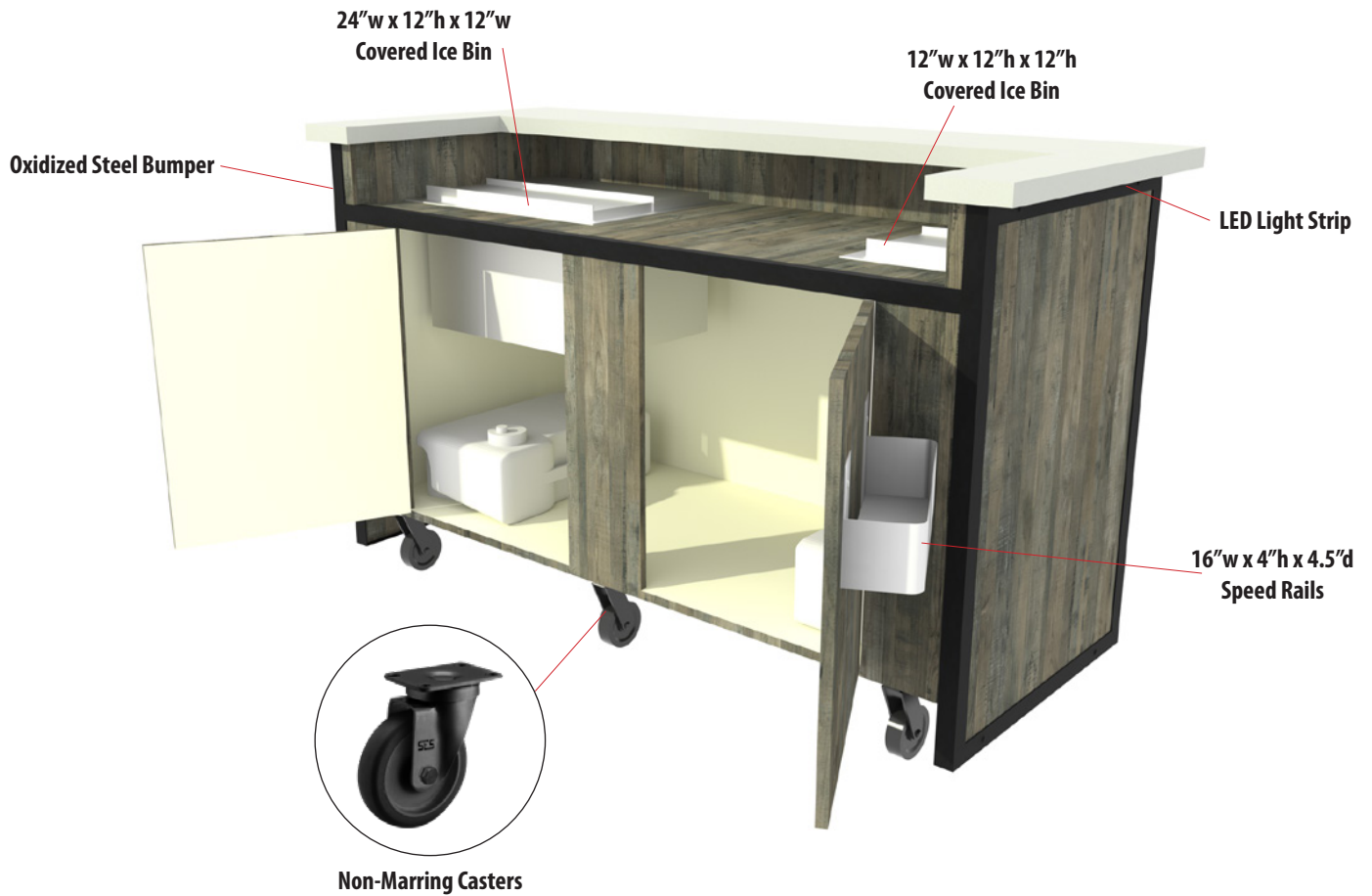

Call us for more info: 1-800-606-6146 -or- sales@coreconceptsinc.com



*Shown in Franklin

Portable Back Bar

features

- Blackened Steel Frame
- Heavy Duty Construction
- 4" Casters with Black Polyurethane Tread
- (2) Locking Casters
- LED Lights on Shelving
- Sliding Door Storage Below

Overall Dimensions - 66.5"l x 24"d x 87"h

*LED Lighting on Shelving



Choose from our standard finishes. Custom finishes available.

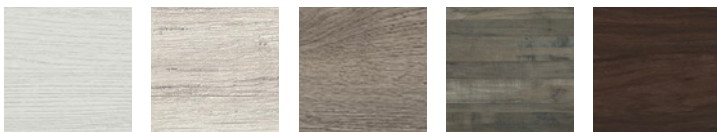

Yarmouth Nantucket Foxboro Franklin Brookline

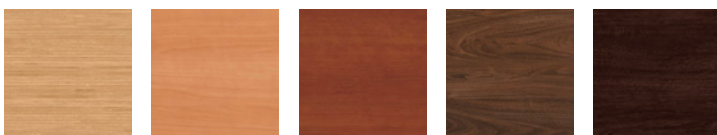

Cambridge Quincy Salem Walpole Boston

Call us for more info: 1-800-606-6146 or sales@coreconceptsinc.com

Portable Back Bar

 **MADE IN THE USA**

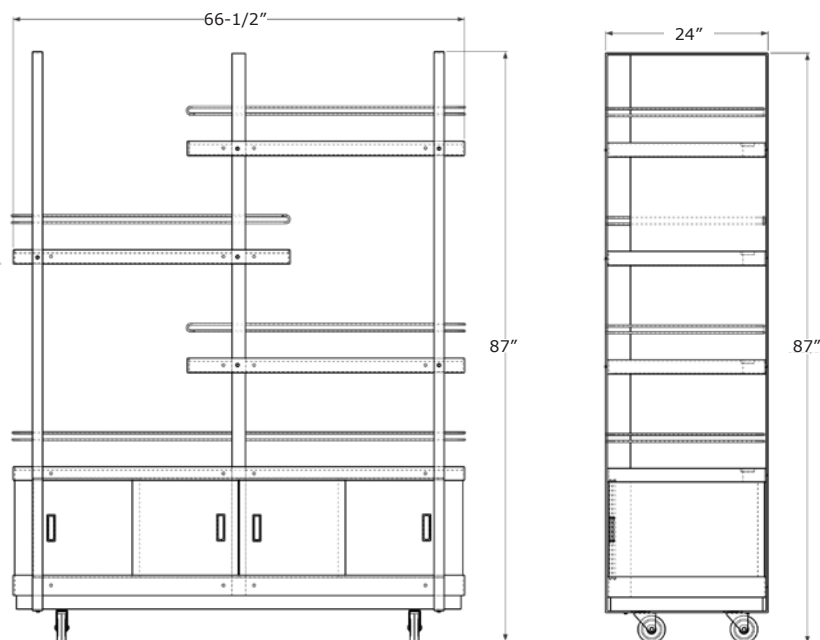

Call us for more info: 1-800-606-6146 -or- sales@coreconceptsinc.com



***Shown in Franklin**

Portable Side Bar

features

- Blackened Steel Frame
- Heavy Duty Construction
- 4" Casters with Black Polyurethane Tread
- (2) Locking Casters
- Open Storage with Adjustable Shelf
- Frame Extends to Hide Casters

Overall Dimensions - 28"l x 28"d x 34"h



***Adjustable Shelf**

Choose from our standard finishes. Custom finishes available.

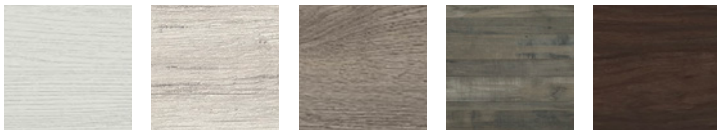

Yarmouth Nantucket Foxboro Franklin Brookline

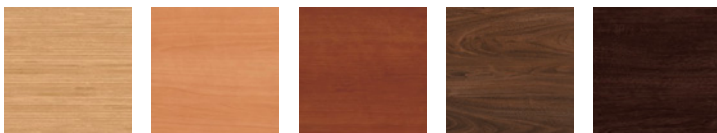

Cambridge Quincy Salem Walpole Boston

Call us for more info: 1-800-606-6146 or sales@coreconceptsinc.com

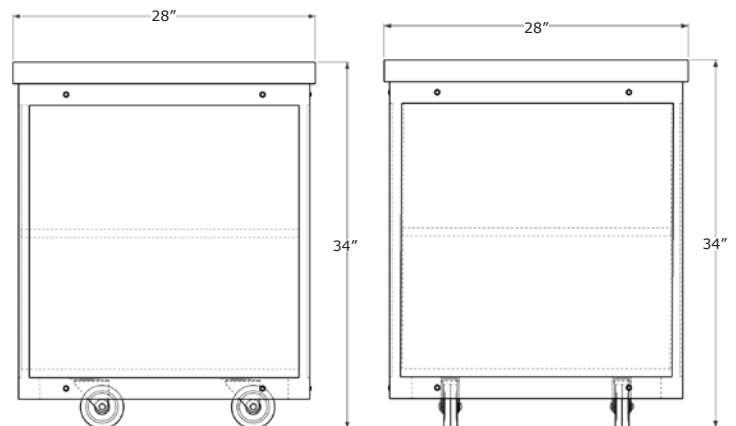



* Shown in Franklin

Partition Wall

features

- Blackened Steel Frame
- Heavy Duty Construction
- 4" Casters with Black Polyurethane Tread
- (2) Locking Casters
- Magnets for Nesting

Overall Dimensions - 98"l x 33.5"d x 90"h

Choose from our standard finishes. Custom finishes available.

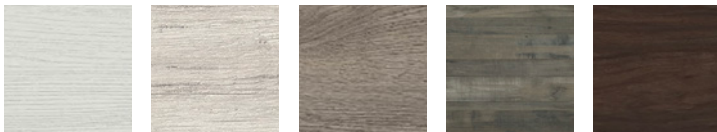

Yarmouth Nantucket Foxboro Franklin Brookline

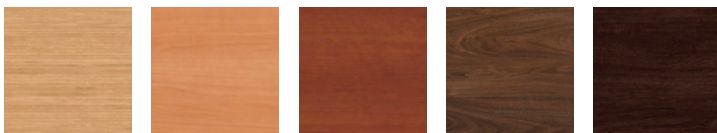

Cambridge Quincy Salem Walpole Boston



* Nestable Design

Call us for more info: 1-800-606-6146 or sales@coreconceptsinc.com

Center Panel Can Be Customized

Blackened Steel Frame

Magnets Allow Multiple Partitions To Stack and Move Together



Non-Marring Casters

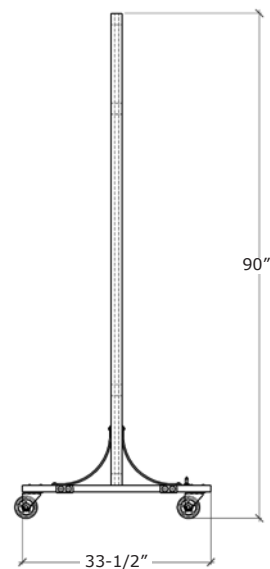
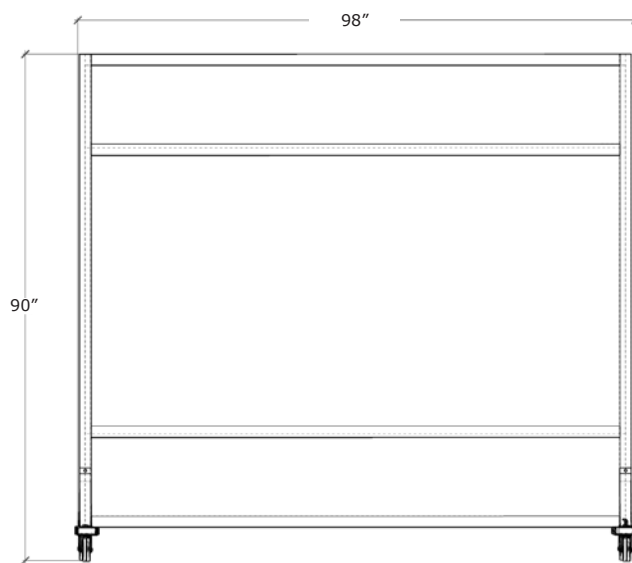

Call us for more info: 1-800-606-6146 -or- sales@coreconceptsinc.com



* Shown in Franklin

Chain Partition Wall

features

- Lightweight Faux Metallic Chain Mesh
- Heavy Duty Frame Construction
- 4" Casters with Black Polyurethane Tread
- (2) Locking Casters

Overall Dimensions - 62"l x 28-1/2"d x 82"h

Choose from our standard finishes. Custom finishes available.

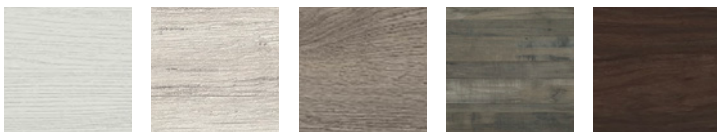

Yarmouth Nantucket Foxboro Franklin Brookline

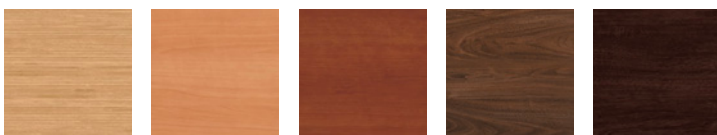

Cambridge Quincy Salem Walpole Boston

Call us for more info: 1-800-606-6146 or sales@coreconceptsinc.com

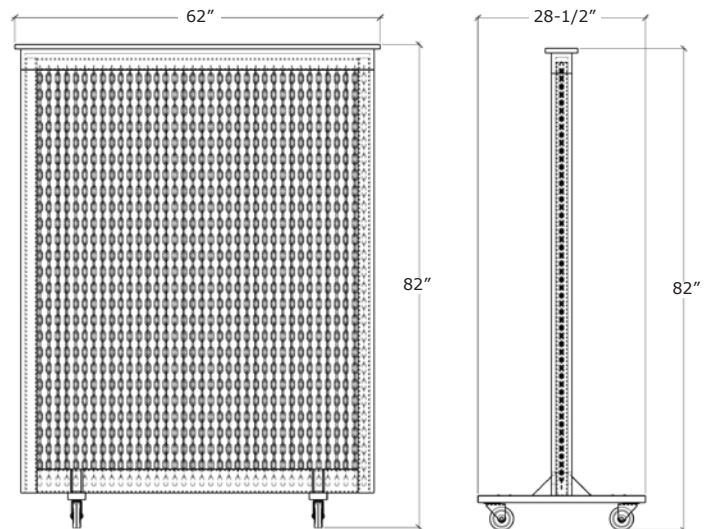

introducing air:core

AIR SANITIZATION SYSTEM

Cleaning the air of an enclosed environment should be a top priority for any workplace, dining, or hospitality setting. Bring your business back to life, and provide your staff and guests with clean air. The air:core filtration system is a large space sanitization solution that uses industrial grade germicidal UV-C lamps and MERV8/HEPA filtration to trap and deactivate Coronavirus and other pathogens in the air, effectively reducing airborne transmission in a space up to 3,000 cubic feet. Multiple units can be combined with air circulators to accommodate larger spaces.

features

- Design based on peer reviewed research and empirical measurements.
- Unique 360° intake design with top surface exhaust
- Powerful 400 cubic feet per minute blower provides 8 air change overs per hour*
- UV-C irradiation to deactivate pathogens. **
- (6) 48" UV-C Bulbs and (6) 36" UV-C Bulbs for sterilization & sanitization **
- MERV8 Prefilter for dust, pollen, & debris
- Medical Grade HEPA Filter traps pathogen/particulate smaller than .15 µm ***
- 5' Cord with lockable casters and entry door

Overall Dimensions - 32" w x 32" d x 54" h

Choose from our standard finishes. Custom finishes and grill patterns available.



Call us for more info: 1-800-606-6146 or sales@coreconceptsinc.com

* Citation: IAQ Conference: IAQ 2010: Airborne Infection Control Committee

** https://www.ashrae.org/file%20library/about/position%20documents/pd_infectiousaerosols_2020.pdf

* Illuminating Engineering Society. (2020). IES Committee Report CR-2-20-V1. New York: IES Photobiology Committee. (<https://media.ies.org/docs/standards/IES%20CR-2-20-V1a-20200507.pdf>)

** Shan Li, C., & Tseng, C.-C. (2005). Inactivation of Virus-Containing Aerosols by Ultraviolet Germicidal Irradiation. Aerosol Science and Technology, 1136-1142.

*** COVID-19 (Coronavirus) Resources for the Air Filtration Industry . Retrieved August 5, 2020, from <https://www.nafahq.org/covid-19-coronavirus-resources-for-the-air-filtration-industry/>



air:core is designed to sanitize the air with 8 air change overs per hour within a maximum sized room of 3000 cubic feet (approx. 16'L x 20'W x 9'H)

